

Installation accessories for Mover SE, TE and S

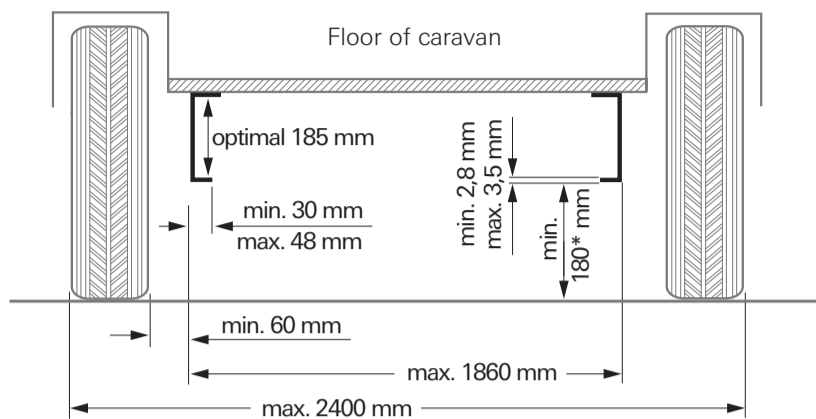

* for loaded vehicle

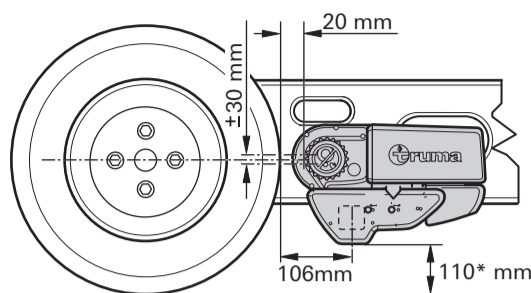

Assembly of Mover

The following distances must be adhered to when the vehicle is swivelled out:

- 20 mm between the Mover roller and the tyres of the vehicle
- ±30 mm this may vary between the median point of the rollers and tyres
- 106 mm between the median point of the fastening tube and the tyres
- 110 mm Minimum floor clearance for loaded vehicle

Standard frame with L-profile or U-profile

Assembly in front of the axle

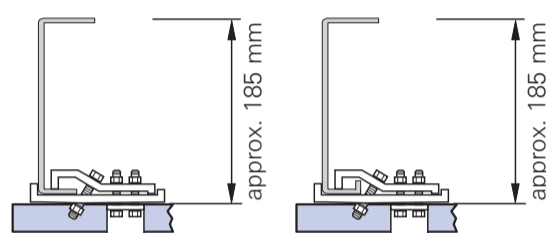
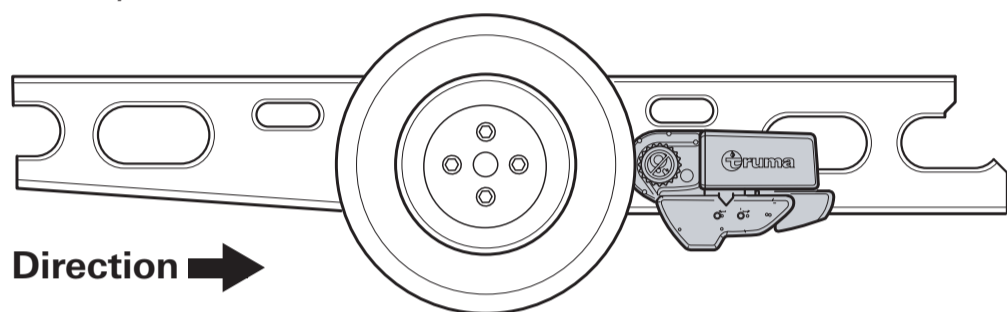

The fastening set included in delivery allows for installation on **L-profile or U-profile** frames (in front of the axle) **without any other accessories**.

Standard frame with L-profile or U-profile

Assembly behind the axle

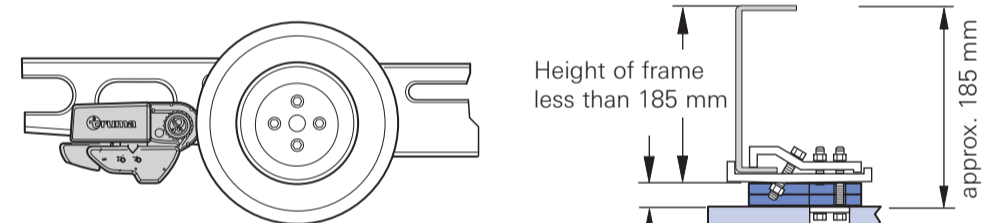

accessories needed to compensate for decreasing height of frame (generally 30 mm):

- 2 x 60010-66000 Spacer plate kit (2 items each)
- 1 x 60010-70000 Set of screws (8 items each)

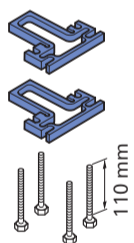

A maximum of 3 spacer plates (45 mm) may be installed to compensate for the height.

Where the height of the frame is **less than 140 mm** the **flat frame kit** must be used.

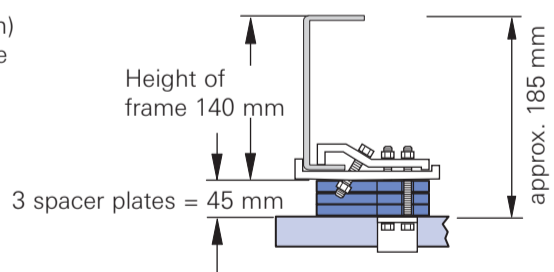

Standard flat frame

Assembly in front of or behind the axle

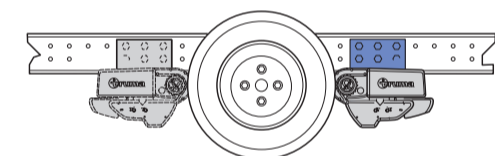

BPW flat frame Vario III one-piece

Assembly in front of or behind the axle

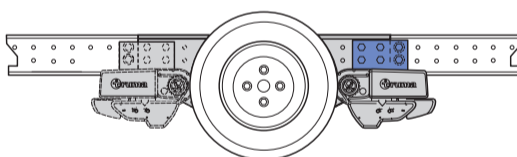

BPW flat frame Vario III two-piece

Assembly in front of or behind the axle

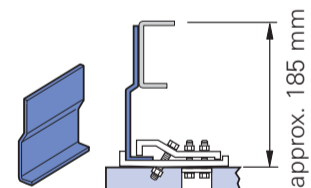
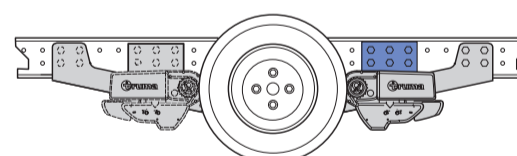

accessories needed to compensate for low height of frame:

- 60010-64900 Flat frame kit (2 items)
- If the chassis has to be drilled into for the purposes of assembly it must be subsequently inspected and approved by an officially recognised (TÜV) expert!

ALKO Vario III

Assembly only possible behind the axle

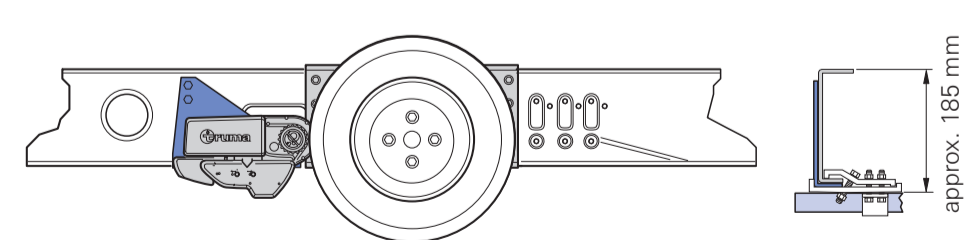

accessories needed to strengthen the light construction frame:
60010-21500 Installation kit ALKO Vario III/AV (2 items)

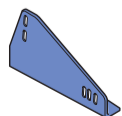

Eriba Touring

Install in front of axle (the waste water pipeline system must be routed if the equipment is being installed behind the axle).

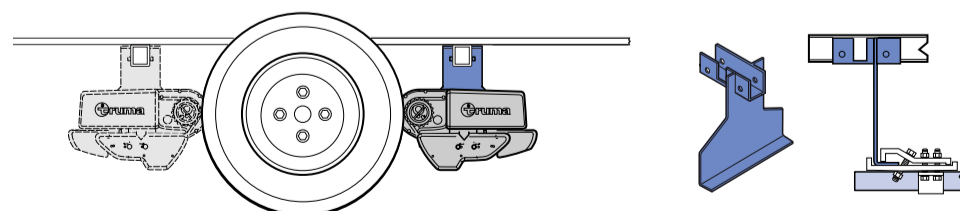

accessories needed to complete the rectangular profile:
60030-09000 Eriba Touring installation kit (2 items)